

# Micro Switch

Z15 Series



## Part Number Description

**Z15** - **1** **2** **B**

<b>1</b> Description	G : Standard	H : High Sensitive ( Only 060, 08 )		
<b>2</b> Head Type	01 : Push Plunger	010 : Pin Push Plunger	10 : Short Push Plunger	03 : Long Push Plunger
	030 : Roller Plunger	031 : Cross Roller Plunger	05 : Lever	052 : Roller Lever
	063 : Hinge Short Lever	062 : Hinge Short Lever	061 : Hinge Long Lever	06 : Hinge Long Lever
	060 : Hinge Long Lever ( Only H )	08 : Hinge Long Lever ( Only H )	09 : Hinge Roller Short Lever	
	07 : Hinge Roller Long Lever	73 : Hinge Roller Long Lever ( Plastic Roller )		

## General Specification

Contact Form	1C		
Contact Material	Ag alloy		
Contact & Contact Distance	Z15G : 0.5mm	Z15H : 0.25mm	
Insulation Resistance	100MΩ min.(at 500VDC)		
Contact Resistance	Max. 50mΩ		
Maximum Inrush Current	Normal Open (N/O) 15A	Normal Close (N/C) 30A	

Contact Ratings	Voltage	Non-Inductive			Inductive		
		Resistance Load	Lamp Load		Inductive Load	Motor Load	
			Normal Open (N/O)	Normal Close (N/C)		Normal Open (N/O)	Normal Close (N/C)
	125VAC	15A	1.5A	3A	15A	2.5A	5A
	250VAC	15A	1.25A	2.5A	15A	1.5A	3A
	500VAC	10A	0.75A	1.5A	6A	0.75A	1.5A
	8VDC	15A	1.5A	3A	15A	2.5A	5A
	14VDC	15A	1.5A	3A	10A	2.5A	5A
	30VDC	6(2)A	1.5A	3A	5(1)A	2.5(1)A	5(1)A
	125VDC	0.5A	0.5A	0.5A	0.05A	0.05A	0.05A
	250VDC	0.25A	0.25A	0.25A	0.03A	0.03A	0.03A

The values in the blanks are ratings of Z15H type switch. The Z15H type switch has AC ratings of 125 V and 250 V. The aforementioned values are steady-state current values.

The inductive load has a power factor of 0.4 or more (AC), and a time constant of 7m/s or less (DC).

The inrush current is ten times larger than steady-state current in the lamp load, and six times, in the motor load.

Operating Speed	0.01mm/sec ~ 0.5m/sec	
Dielectric Strength	2000VAC 1 Minute	
Life Cycle	Electrical	Min. 500,000
	Mechanical	Min. 20,000,000
Vibration Resistance	10Hz ~ 55Hz Durable amplitude 1.5mm	
Shock Resistance	Malfunctional	Max. 30G
	Destruction	Max. 100G
Ambient Temperature	-25°C ~ +80°C(with no icing)	
Ambient Humidity	35% ~ 85% RH	
Tightening Torque	1.2N·m (12.24kgf·cm)	







☞ This is the case for the push-button type (The values are for the actuator for the lever type).

In the types other than the push-button type, the mechanical life is 10 million times, and the operating error is 1 ms or less.

# Micro Switch

## Z15 Series

### Product Selection

	Part Number	Head Type	OF	RF	PT	OT	MD	FP	OP	KS
	Z15G - 01B	Push Plunger	250 ~ 350gf (2.45 ~ 3.43N)	114gf (1.12N)	0.4 mm	0.13 mm	0.05 mm		15.9 ± 0.4 mm	Z4G1P01B
	Z15G - 010B	Pin Push Plunger	250 ~ 350gf (2.45 ~ 3.43N)	114gf (1.12N)	0.4 mm	1.6 mm	0.05 mm		28.2 ± 0.5 mm	Z4G1P03B
	Z15G - 10B	Short Push Plunger	250 ~ 350gf (2.45 ~ 3.43N)	114gf (1.12N)	0.4 mm	1.6 mm	0.05 mm		21.5 ± 0.5 mm	Z4G1P09B
	Z15G - 03B	Long Push Plunger	250 ~ 350gf (2.45 ~ 3.43N)	114gf (1.12N)	0.4 mm	5.5 mm	0.05 mm		21.8 ± 0.8 mm	Z4G1P05B
	Z15G - 030B	Roller Plunger	250 ~ 350gf (2.45 ~ 3.43N)	114gf (1.12N)	0.4 mm	3.58 mm	0.05 mm		33.4 ± 1.2 mm	Z4G1P07B
	Z15G - 031B	Cross Roller Plunger	250 ~ 350gf (2.45 ~ 3.43N)	114gf (1.12N)	0.4 mm	3.58 mm	0.05 mm		33.4 ± 1.2 mm	





## Product Selection

	Part Number	Head Type	OF	RF	PT	OT	MD	FP	OP	KS
	Z15G - 05B	Lever	141 gf (1.38N)	14gf (0.14N)		1.6 mm	1.3 mm	20.6 mm	17.4 ± 0.8 mm	Z4G1R01B
	Z15G - 052B	Roller Lever	141 gf (1.38N)	14gf (0.14N)		1.6 mm	1.3 mm	31.8 mm	28.6 ± 0.8 mm	Z4G1R03B
	Z15G - 063B	Hinge Short Lever	160 gf (1.57N)	28gf (0.27N)		2.0 mm	1.0 mm	24.8 mm	19.0 ± 0.8 mm	Z4G1R05B
	Z15G - 062B	Hinge Short Lever	95 gf (0.95N)	18gf (0.18N)		4.2 mm	0.95 mm	26.2 mm	19.0 ± 0.8 mm	
	Z15G - 061B	Hinge Long Lever	80gf (0.78N)	15.5gf (0.15N)		4.8 mm	1.12 mm	27.2 mm	19.0 ± 0.8 mm	
	Z15G - 06B	Hinge Long Lever	70gf (0.69N)	14gf (0.14N)		5.6 mm	1.27 mm	28.2 mm	19.0 ± 0.8 mm	Z4G1L01B

# Micro Switch

## Z15 Series

### Product Selection

	Part Number	Head Type	OF	RF	PT	OT	MD	FP	OP	KS
	Z15H - 060B	Hinge Long Lever	6gf (58.8 mN)	0.5gf (4.90N)	19.8 mm	10.0 mm	2.0 mm		19.8 ± 1.6 mm	
	Z15H - 08B	Hinge Long Lever	4gf (39.2N)	0.3gf (2.94N)	10.0 mm	6.0 mm	3.0 mm		20.0 ± 1.0 mm	Z4G1P05B
	Z15G - 09B	Hinge Roller Short Lever	160gf (1.57N)	42g (0.41N)		2.4 mm	0.5 mm	32.5 mm	30.2 ± 0.4 mm	Z4G1L07B
	Z15G - 07B	Hinge Roller Long Lever	100 gf (0.98N)	22gf (0.22N)	4.0 mm	1.02 mm		36.5 mm	30.2 ± 0.8 mm	Z4G1L03B
	Z15G - 073B	Hinge Roller Long Lever (Plastic Roller)	100 gf (0.98N)	21gf (0.21N)	4.0 mm	1.6 mm		47.5 mm	41.2 ± 0.8 mm	

Dimension

unit : mm

Z15G - 01B

Z15G - 010B

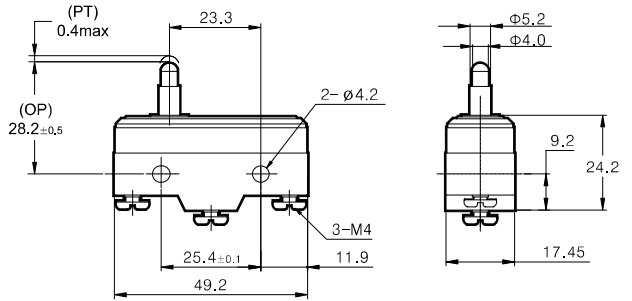
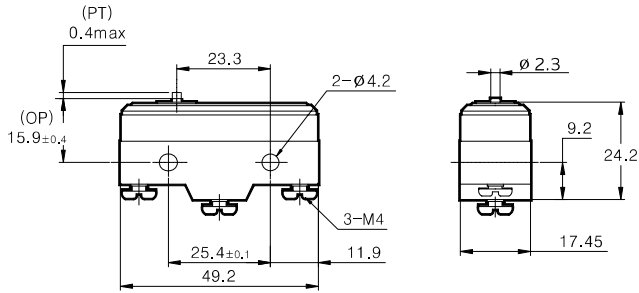

Z15G - 10B

Z15G - 03B

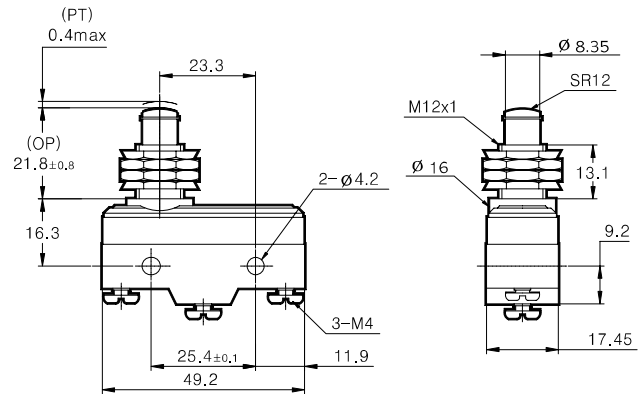
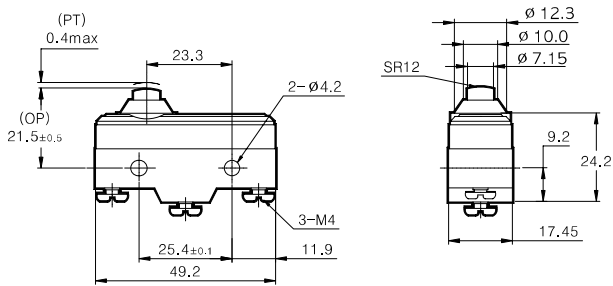

Z15G - 030B

Z15G - 031B

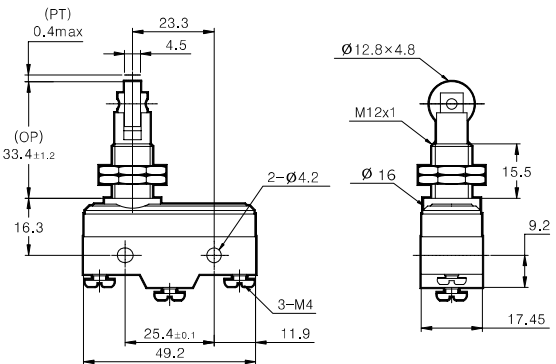
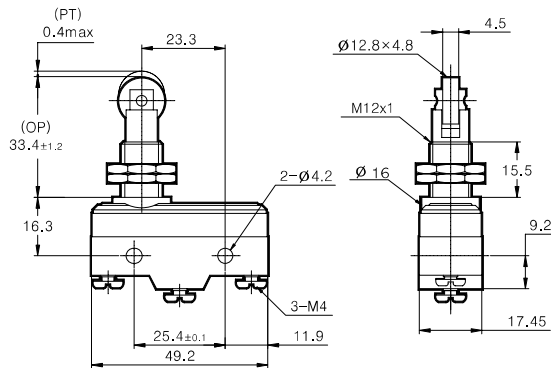

# Micro Switch

Z15 Series

Dimension

unit : mm

Z15G - 05B

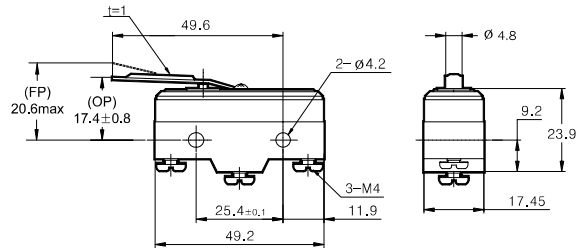

Z15G - 052B

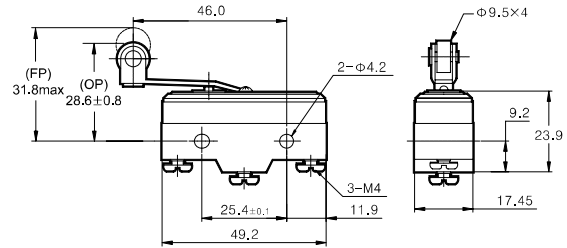

Z15G - 063B

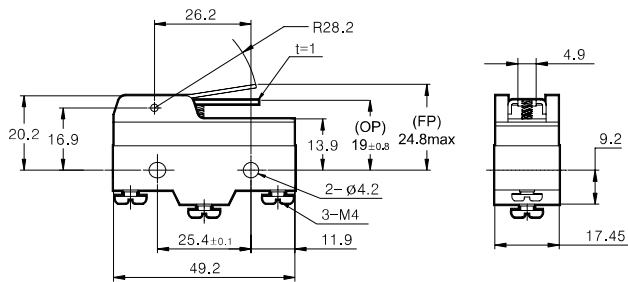

Z15G - 062B

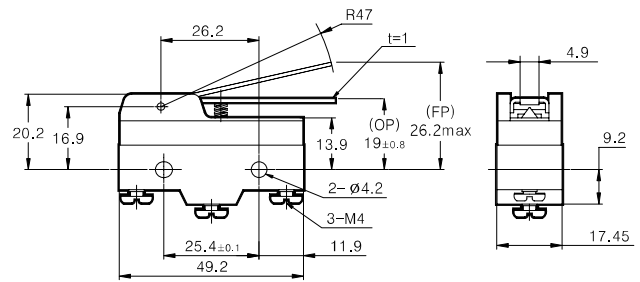

Z15G - 061B

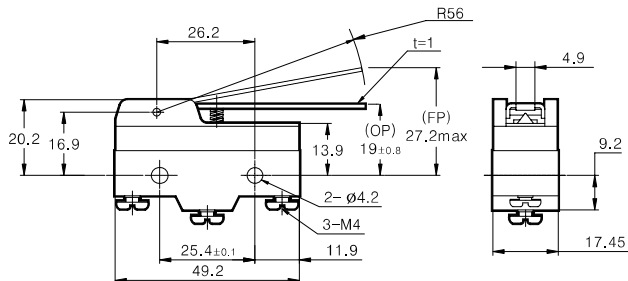

Z15G - 06B

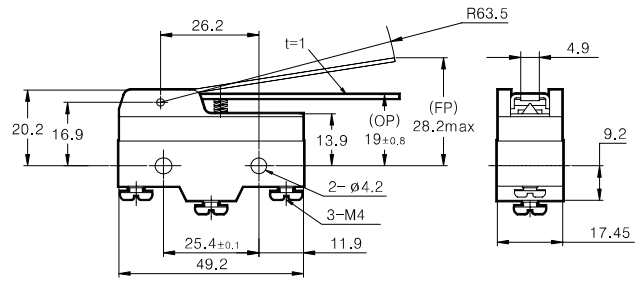

Dimension

unit : mm

Z15H - 060B

Z15H - 08B

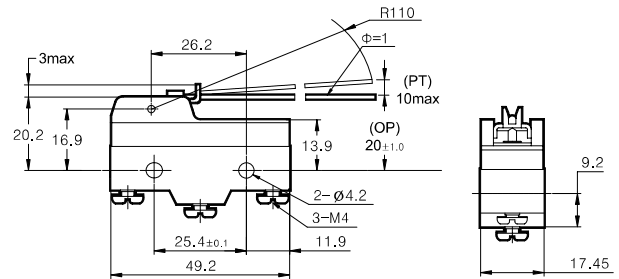
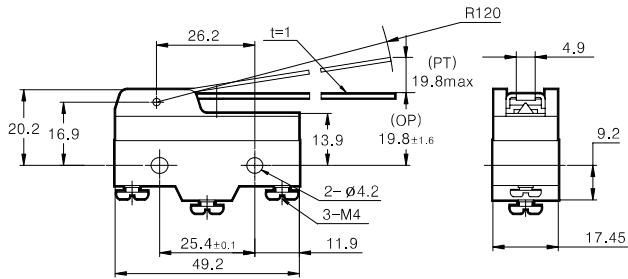

Z15G - 09B

Z15G - 07B

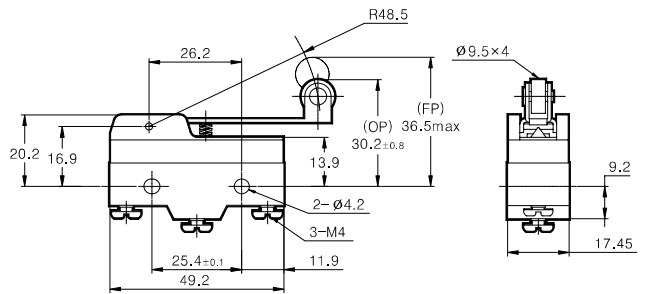
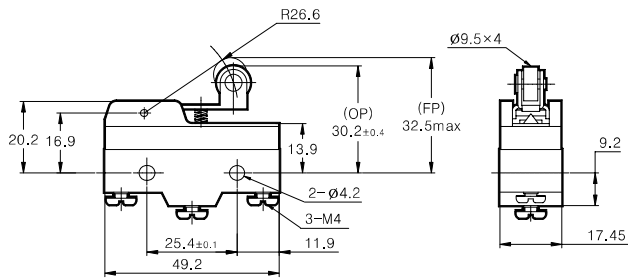

Z15G-073B

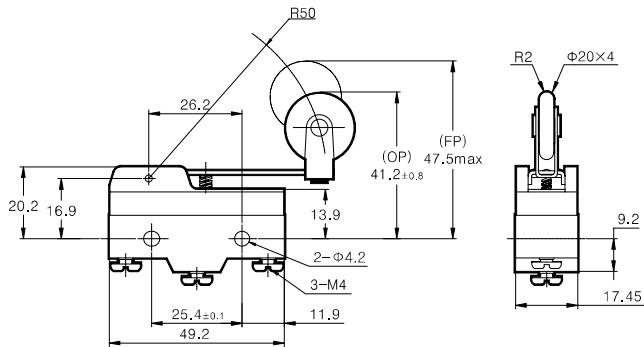

# Micro Switch

Z15 Series

## Dimension

unit : mm

### Diagram

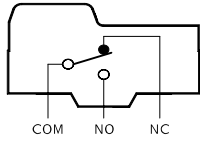

COM : Common Terminal  
NO : Normal Open Terminal  
NC : Normal Close Terminal

### Panel Cut Out

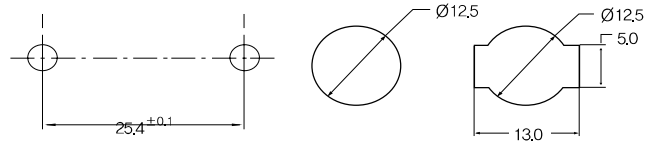

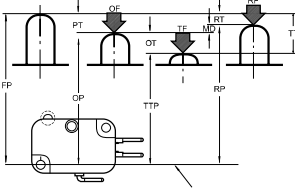
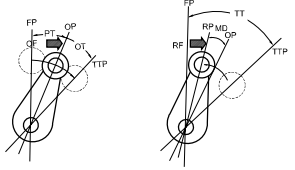
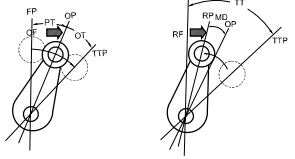

## Glossary

Operating characteristics	Category	Abbr.	Term	Unit	Definition
	Force	Force required for operation	OF	g, kg g-mm	Force on the actuator required for the motion from the free position to the operating position
		Restoring force	RF	g, kg g-mm	Force on the actuator required for the motion from the operating limit position to the restoring position
		Force required for entire motion	TF	g, kg g-mm	Force on the actuator required for the motion from the operating position to the operating limit position
	Motion	Motion to the operating position	PT	mm, deg	Distance or angle from the free position of the actuator to the operating position
		Motion after operation	OT	mm, deg	Distance or angle from the operating position of the actuator to the operating limit position
		Hysteresis distance	MD	mm, deg	Distance or angle from the operating position of the actuator to the restoring position
		Total motion	TT	mm, deg	Distance or angle from the free position of the actuator to the operating limit position
	Position	Free position	FP	mm, deg	The position of the operating part when no force is applied from outside
		Operating position	OP	mm, deg	The position of the actuator when the external force is applied to the actuator and the moving contact reverses from the free position
		Restoring position	RP	mm, deg	The position of the actuator when the external force to the actuator is reduced and the moving contact reverses from the operating position to the free position
		Operating limit position	TTP	mm, deg	The position of the actuator when the actuator reaches the actuator stop position

## Option

(mm)

### SAFETY COVER

ZSC1

ZSC2

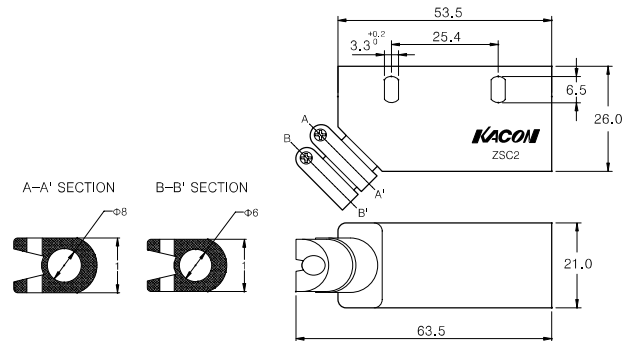
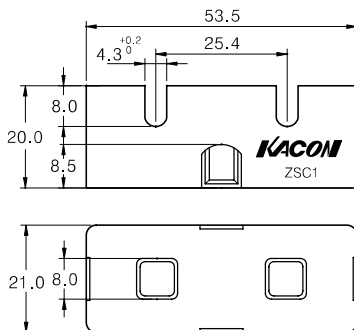

# Micro Switch

## Z15 Series

### Electrical Caution

#### ● Electrical conditions

Check the rating because the contact has different breaking capacities for AC and DC.

For microvoltage and microcurrent, use the contact for microload.

Check the inrush current, steady-state current and inrush time.

Measure the contact resistance at DC 6 V ~ DC 8 V and 1A

(Comply with the voltage drop method for the microcurrent).

The difference between the steady-state current and inrush current may vary according to the load type. Check the inrush current value.

#### ● The ratings are based on the following conditions.

Inductive load: power factor 0.4 or more (AC), time constant 7 ms or less (DC)

Lamp load: Inrush current  $\geq 10 \times$  Steady-state current

Motor load: Inrush current  $\geq 6 \times$  Steady-state current

#### ● Notes for the circuit

In the inductive load breaking circuit, the surge and inrush current at the opening/closing of the circuit may cause contact problems.

Therefore, it is desirable to insert a protection circuit as follows.

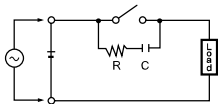

Normally used for DC circuits.  
A resistor of several ohms is required.  
When used for AC circuit, the load must be small.  
R:  $10 \Omega \sim 100 \Omega$   
C:  $0.05 \sim 0.1 \mu\text{F}$

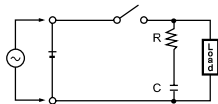

Used both for AC and DC circuits.  
R:  $10 \Omega$   
C:  $0.1 \sim 0.2 \mu\text{F}$

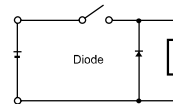

Used only for DC circuits.  
Select a diode with sufficient margin to the inverse withstand voltage.

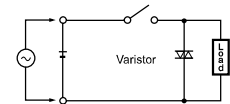

Used both for AC and DC circuits.  
Select a varistor that is 1.5 times higher than the power supply voltage.

Do not connect different polarities and types of power to one switch contact.  
Do not apply the voltage between contacts (This causes the mixed contact and contact weld)

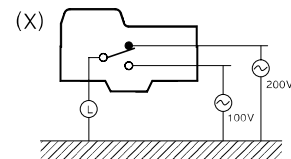

#### ● Application to the electronic circuits (low voltage and current)

1. The micro switch generates bouncing and chattering between contacts when it is switched on/off.  
This causes troubles, including noises and wrong pulses, to the electronic circuits or acoustic devices.

2. When bouncing and chattering cause problems, studies are required to provide an absorption circuit in addition to the CR circuit.

3. In the areas that require high contact reliability, the Ag contacts, which have been widely used, are hardly used.  
Au contacts have high performances for microvoltage and microcurrent.

### Mechanical Caution

#### ● Mechanical conditions

Select the actuator according to the operating method.

Do not apply excessive force to the actuator.

Check the switching speed and frequency.

- 1) If the switching speed is too slow and unstable, poor contact or contact weld may occur.
- 2) If the switching speed is too high, switching may not be completed.

#### ● Precautions

The operating method, cam or dog type, frequency, motion after switching significantly influence the product life and accuracy. Use the cams or dogs that have general shapes.

Do not allow the load to one side of the switch actuator, and prevent the partial wear.

Adjust the actuator so that it does not pass beyond OT.

The proper operating stroke is 70% ~ 100% of the standard OT.

If OT passes beyond the limit, it may cause failure.

Use the switch considering the characteristics of the actuator.

In the case of the roller arm lever, do not apply force in the arrowed direction in the figure.

Avoid the modification of the operating position by processing the actuator.

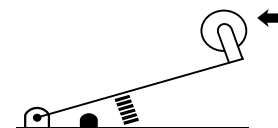

## Mounting Caution

---

### ● Environment

If the switch is not waterproof and sealed, do not use the product in the environment where oil or water scatters or bursts.  
Use the protective cover to avoid direct exposure to the liquid. A limit switch is more proper for this case than the standard switch.  
Contact us when using the limit switch outside or with special cutting oil so that the deterioration of the switch material is expected.  
Place the switch on the place where it is not directly exposed to the processing waste or dusts.  
Protect the actuator and switch body from the cutting waste or foreign matters.  
Do not use the switch in the temperature and air conditions other than specified.  
The allowable ambient temperature varies according to the product type (Check the product specifications).  
In the case of abrupt thermal change, the heat impact deforms the switch and causes failure.  
When mounting the switch in the place where operating errors or accidents may happen in the normal operator or equipment conditions, additional measures are required.

### ● The panel mounting type

Use M4 screws for fixing. Mount the product firmly using flat or spring washers.  
The proper tightening torque is 12 ~ 15 kgf·cm (1.18 ~ 1.47 N·m).  
The proper tightening torque for the hexagonal nut of the actuator is 50 kgf·cm (4.9 N·m).  
When mounting the panel mounting pushbutton type on the side using screws, remove the hexagonal nuts from the actuator part.  
For the connection with lead terminals, use crimp terminals at a tightening torque of 8 ~ 12 kgf·cm (0.78 ~ 1.18 N·m). (Recommended wire spec.: VCT 1.25 mm<sup>2</sup> twowire, three-wire)

### ● The drip-proof type

Do not soak the product in oil because this product is not completely oil-tight.  
Avoid using this product in the condition where temperature abruptly changes.

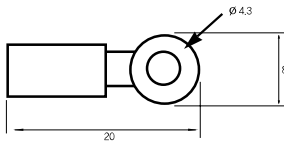

※ Specifications and materials can change without prior notice.